



Fantech

Installation Instructions for Model: DBLT4W Secondary Dryer Lint Trap



READ AND SAVE THESE INSTRUCTIONS

INSTALLATION:

The DBLT4W is a Secondary Dryer Lint Trap used when installing a Fantech Dryer Booster fan less than the recommended distance of 15 feet from the back of the dryer.

- The Lint Trap must be installed so it is easily accessible to the dryer user.
- It is recommended the dryer user inspect for lint accumulation prior to operation of the dryer.

REMOVE LINT AS REQUIRED TO KEEP THE SCREEN CLEAN

NOTE: Normally the DBLT4W is installed in the dryer duct just above the dryer.

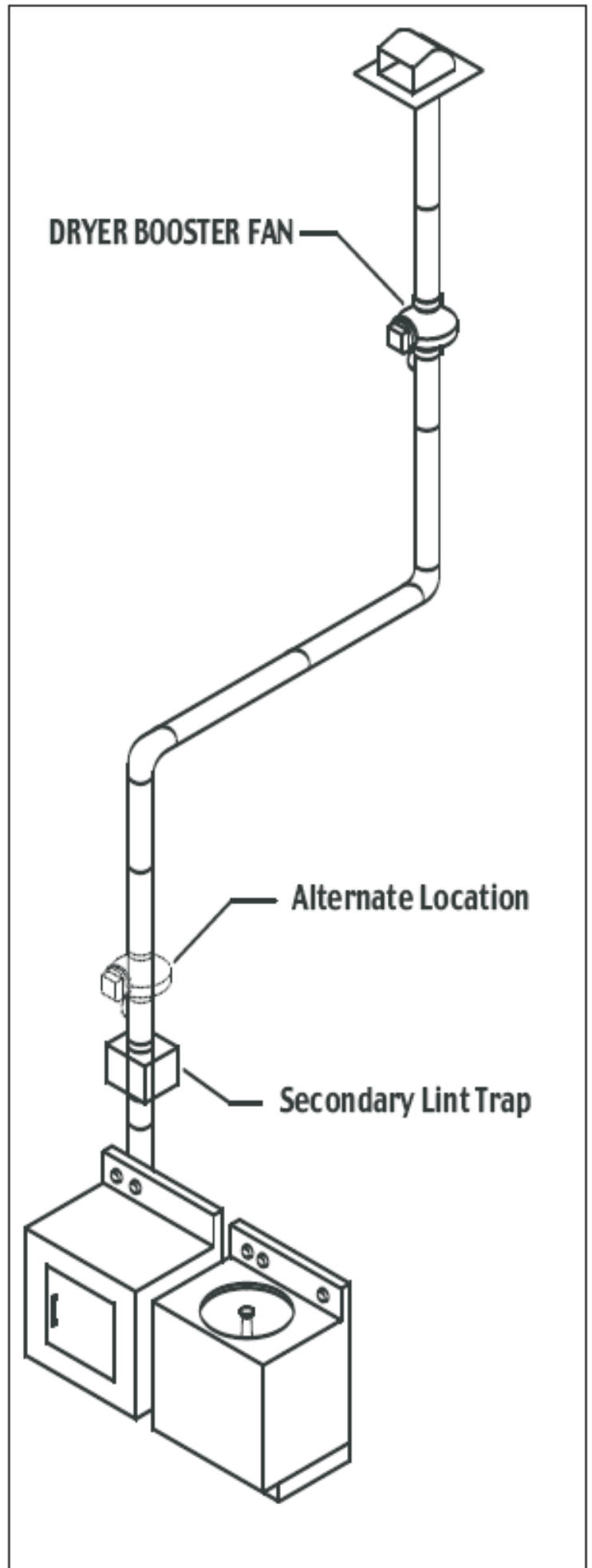
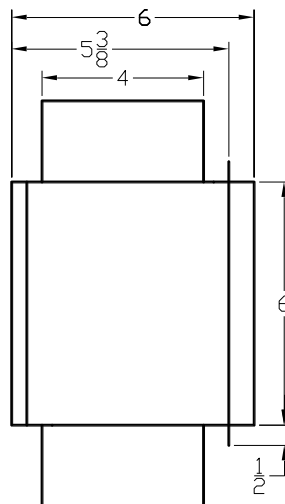
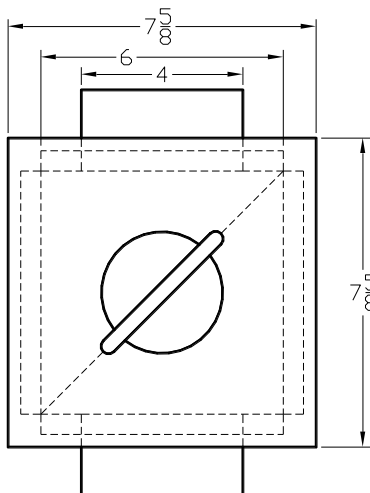

FIVE (5) YEAR WARRANTY

This warranty supersedes all prior warranties

DURING ENTIRE WARRANTY PERIOD:

FANTECH will repair or replace any part which has a factory defect in workmanship or material. Product may need to be returned to the Fantech factory, together with a copy of the bill of sale and identified with RMA number.

FOR FACTORY RETURN YOU MUST

- Have a Return Materials Authorization (RMA) number. This may be obtained by calling FANTECH either in the USA at 1.800.747.1762 or in CANADA at 1.800.565.3548. Please have bill of sale available.
- The RMA number must be clearly written on the outside of the carton, or the carton will be refused.
- All parts and/or product will be repaired/replaced and shipped back to buyer; no credit will be issued.

OR

The Distributor may place an order for the warranty part and/or product and is invoiced.

The Distributor will receive a credit equal to the invoice only after product is returned prepaid and verified to be defective.

FANTECH WARRANTY TERMS DO NOT PROVIDE FOR REPLACEMENT WITHOUT CHARGE PRIOR TO INSPECTION FOR A DEFECT. REPLACEMENTS ISSUED IN ADVANCE OF DEFECT INSPECTION ARE INVOICED, AND CREDIT IS PENDING INSPECTION OF RETURNED MATERIAL. DEFECTIVE MATERIAL RETURNED BY END USERS SHOULD NOT BE REPLACED BY THE DISTRIBUTOR WITHOUT CHARGE TO THE END USER, AS CREDIT TO DISTRIBUTOR'S ACCOUNT WILL BE PENDING INSPECTION AND VERIFICATION OF ACTUAL DEFECT BY FANTECH.

THE FOLLOWING WARRANTIES DO NOT APPLY:

- Damages from shipping, either concealed or visible. Claim must be filed with freight company.
- Damages resulting from improper wiring or installation.
- Damages or failure caused by acts of God, or resulting from improper consumer procedures, such as:
 1. Improper maintenance
 2. Misuse, abuse, abnormal use, or accident, and
 3. Incorrect electrical voltage or current.
- Removal or any alteration made on the FANTECH label control number or date of manufacture.
- Any other warranty, expressed, implied or written, and to any consequential or incidental damages, loss or property, revenues, or profit, or costs of removal, installation or reinstallation, for any breach of warranty.

WARRANTY VALIDATION

- The user must keep a copy of the bill of sale to verify purchase date.
- These warranties give you specific legal rights, and are subject to an applicable consumer protection legislation. You may have additional rights which vary from state to state.



Submitted by: _____	Date: _____
Qty: _____	Model #: _____
Comments: _____ _____	
Project #: _____	
Location: _____	
Architect: _____	
Engineer: _____	
Contractor: _____	

United States

10048 Industrial Blvd.

Lenexa, KS 66215

Phone: 800.747.1762; 913.752.6000

Fax: 800.487.9915; 913.752.6466

www.fantech.net; info@fantech.net

Canada

50 Kanaflykt Way,

Bouctouche, NB E4S 3M5

Phone: 800.565.3548; 506.743.9500

Fax: 877.747.8116; 506.743.9600

www.fantech.ca; info@fantech.ca

Fantech, reserves the right to modify, at any time and without notice, any or all of its products' features, designs, components and specifications to maintain their technological leadership position.

Item #: 450224
Rev Date: 060313