

- Full stainless exterior!
- Non-corroding poly liner!
- All-poly cart for added durability!



Model ITS1350SG-60 (with Totes accessory in cart)

Ice flows into the castered cart when hopper door is opened, allowing fast, convenient ice removal.



**Optional Ice Totes accessory** allows easy, safe ice distribution! Cart holds 68kg (150 lbs) of ice when Totes are used.

Elevated bin and cart systems. Cart(s) slide into bay(s) below bin for gravity loading with ice when shutter door is opened. Widths from 31" (788mm) to 90" (2286mm) and capacities from 700 lbs (318kg) to 3250 lbs (1474 kg) of ice, excluding carts. Each cart stores an additional 240 lbs (109kg) of ice. Full stainless bin and base exterior standard.

#### Labor-saving design increases convenience and safety

- Gravity loading of ice saves time, eliminates shoveling
- Castered cart rolls easily, quickly to area of use
- Totes™ accessory allows safe, easy ice distribution in displays, salad bars, ice dispensers

#### All-polyethylene cart provides a better way to move ice within your facility

- Durable, easy-to-clean poly eliminates dents, scratches
- All-poly material reduces damage to walls and fixtures from careless cart drivers
- Oversized wheels make maneuvering easy
- Wide, shallow cart design facilitates removal of ice
- Cart drains to bin drain system when parked in bay

#### Non-corroding poly liners and hoppers

- Eliminates pitting and staining of liner
- Provides exceptional durability

#### Totes accessory simplifies ice distribution

- Six rugged polyethylene Totes nest in cart
- Eliminates need to shovel ice from cart
- Easy, safe way to distribute ice in displays
- Slim Totes design fits easily below breath protectors

#### Other quality construction features

- Full stainless bin and base standard
- Heavy-duty base with built-in drain for bin and cart
- Single, reversible drain connection
- Durable polyethylene lift door with PowerHinge™ on ITS700-31, inspection window on ITS500-31
- Stainless tops custom-cut for specific icemaker(s)

#### Accessories

- Ice Totes (set of 6, one set per cart) (item# ABICETOTP)
- Additional ice transport cart(s)
- Drain pan (required for some Vogt and Howe icemakers; consult factory)
- Center partition for 2-bay systems; off-set partition for 3-bay systems
- Plastic shovel (item# ABICSHOVEL)
- Ice paddle and hanging bracket (item# ABICEPADDL)

U.S. Patents 5,211,030  
& 5,797,514

**Front View  
ITS700SG-31**  
(without cart in bay)  
ITS500NS has  
sliding window only

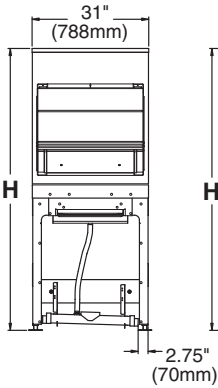

**Front View  
ITS1350SG-60**  
(without carts in bays)  
ITS2250SG has sliding  
window at top of bin

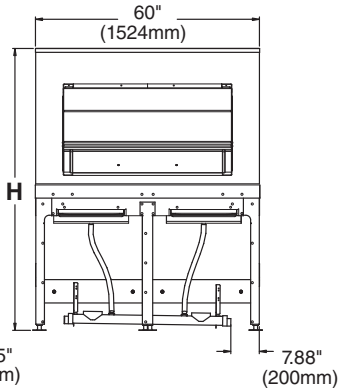

**Front View – ITS3250SG-90**  
(without carts in bays)  
ITS1700SG has no sliding window

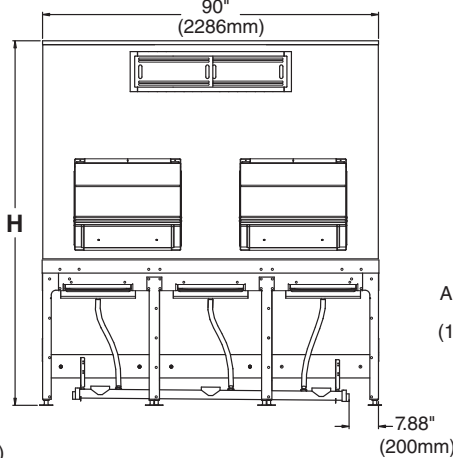

**All Models**

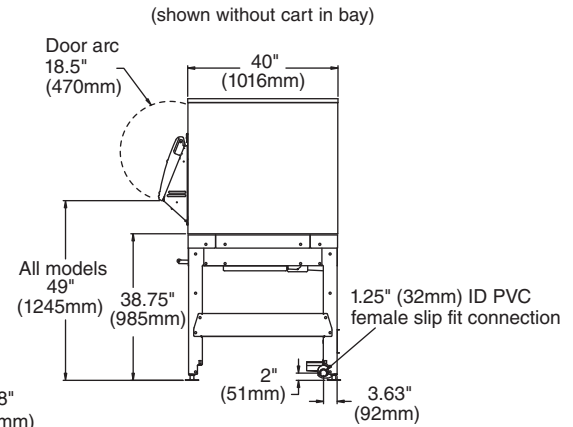

**General Notes**

- Clearance required to pull cart from bay – minimum 48" (1220mm), optimal 54" (1372mm)
- Follett recommends installation of a floor drain with grate with all ice storage bins
- Drain connection is reversible to exit at left or right side of unit

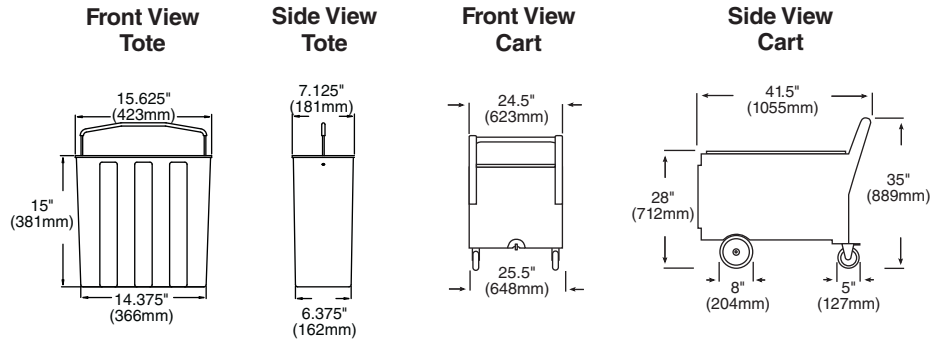

Model Number	Cubic Volume cu ft (m)	Max. Bin Cap. lb (kg) <sup>1</sup>	Max. Cap. with Carts lb (kg) <sup>1,2</sup>	No. Carts	Width in (mm)	Depth in (mm) <sup>3,5</sup>	Depth with Door in (mm) <sup>3,5</sup>	Height (H) with Legs in (mm) <sup>6</sup>	Required Access in (mm) <sup>4</sup>	Approximate Ship Wt. lb (kg) <sup>5</sup>
ITS500NS-31	12.7 ( .36)	382 ( 174)	622 ( 283)	1	31 ( 788)	40 (1016)	40 (1016)	60 (1524)	32 ( 813)	446 (203)
ITS700SG-31	21.7 ( .61)	652 ( 296)	892 ( 405)	1	31 ( 788)	40 (1016)	48 (1220)	75 (1905)	32 ( 813)	467 (212)
ITS1350SG-60	44.2 (1.25)	1327 ( 602)	1567 ( 711)	2	60 (1524)	40 (1016)	48 (1220)	75 (1905)	41 (1042)	849 (386)
ITS2250SG-60	71.1 (2.01)	2133 ( 968)	2373 (1077)	2	60 (1524)	40 (1016)	48 (1220)	97 (2464)	41 (1042)	972 (441)
ITS1700SG-90	58.2 (1.65)	1716 ( 779)	1986 ( 901)	3	90 (2286)	40 (1016)	48 (1220)	70 (1778)	41 (1042)	1203 (645)
ITS3250SG-90	108.5 (3.07)	3255 (1477)	3495 (1586)	3	90 (2286)	40 (1016)	48 (1220)	97 (2464)	41 (1042)	1370 (622)

**Notes:**

- 1 Computed on cubic volume of bin. Does not reflect cart capacity or voids that can occur due to pyramiding.
- 2 Each cart holds 240 lbs (109kg) without optional Totes, 150 lbs (68kg) with Totes.
- 3 Door assemblies remove easily (4 screws) if necessary for installation access.
- 4 Required clearance for installation access through doors (may require removal of door assembly).
- 5 Add 2" (51mm) to depth and 10 lbs (4.5kg) to shipping weight when drain pan accessory used.
- 6 Special top required for icemakers weighing more than 1000 lbs (454kg). Add 2.125" (54mm) to height. Contact factory.

PowerHinge and Totes are trademarks of Follett Corporation.  
SMARTGATE is a registered trademark of Follett Corporation, registered in the US.  
Follett reserves the right to change specifications at any time without obligation. Certifications may vary depending on country of origin.