

# BAI web

## thermostat

# Owner's Manual



[ S/N LABEL HERE ]

Document # BW-WT2DOC

BAYweb Thermostat Model BW-WT2 Owner's Manual  
Copyright © 2009 Bay Controls, LLC  
Part Number: BW-WT2DOC  
Revision: 1.1 November 11, 2009

BAYweb and Plug-N-Go are trademarks of Bay Controls, LLC.  
Patent pending technologies are used in the BAYweb Thermostat.

# Table of Contents

Introduction.....	1
About This Manual.....	1
Safety Precautions.....	1
Labels.....	2
Limited Warranty.....	3
Limitation on Liability.....	3
Unauthorized Repair.....	3
Installation.....	4
Overview.....	4
Identify Wiring.....	6
Install Control Module.....	8
Install Thermostat Keypad.....	10
Connect to the Internet.....	12
Configure the Thermostat.....	13
Test Operation.....	14
Operation.....	15
Using the Thermostat Keypad.....	15
Using the Web Portal.....	15
Using Your Mobile Phone.....	16
Occupancy Sensing.....	16
Implementing Occupancy Sensing.....	16
Testing Occupancy Sensing.....	17
Occupancy Sensing with Multiple Thermostats.....	17
Alerting.....	18
Implementing Alerting.....	18
Testing Alerting.....	18
Reference.....	19
Thermostat Keypad.....	19
Error Codes.....	19
Control Module.....	20
Alert Inputs.....	20
Thermostat Connector.....	20
Furnace/AC Connector.....	21
LAN Port.....	21
Line Power.....	21
Status Indicators.....	21
Troubleshooting.....	22
Solutions to Problems.....	23
Obtaining Support.....	25
Zone Control.....	27
Thermostat Connections.....	27
Thermostat Wiring.....	27
Control Module Terminals.....	27
Specifications.....	28

## Introduction

Thank you for purchasing the BAYweb Thermostat. You now have one of the most advanced Heating, Ventilating, and Air Conditioning (HVAC) control systems available today.

This thermostat is easily installed by home owners or HVAC professionals. It can be used to replace an existing thermostat or for installation with new heating or cooling equipment.

This model of the BAYweb Thermostat (BW-WT2) is designed for use with conventional or heat pump based systems, that use single or multistage stage control.

## About This Manual

This manual contains the information necessary for installing and operating the BAYweb Thermostat. However, since installations may vary, these instructions may not cover all details or variations in the equipment supplied or every question that may possibly arise during use.

If a question or situation develops which is not answered directly in this manual, contact BAYweb support for specific answers and advice.

You should become familiar with the contents of this manual before the thermostat is put into service. This is particularly important with regard to the safety precautions listed in the Introduction section, and those included at relevant points in other sections of this manual.

Note that this manual is updated periodically. You can download the latest version at [www.bayweb.com](http://www.bayweb.com).



**CAUTION:** Read, be sure to clearly understand, and then carefully follow all of the directions and procedures included in this manual. Failure to adhere to the guidelines and specific instructions provided could cause equipment damage and serious personal injury or death.

## Safety Precautions

Low voltage thermostats, including the BAYweb Thermostat, use 24 VAC control signals limited to 3.2 amperes to interface to your furnace and air conditioning equipment. These low voltage control signals do not normally represent an electric shock hazard unless used in an environment for which the equipment was not designed for, such as a wet location.

The BAYweb Thermostat is independently powered from a line cord connected to a standard 120 VAC electrical outlet. This line voltage does represent an electrical shock hazard if improperly used. Do not cut or modify the line cord in any way. Do not use a damaged line cord. Do not remove the cover of the control module. Do not expose the control module to water. Do not plug in the control module when wet.

Bay Controls, LLC. expressly disclaims responsibility or liability for any injury or damage

caused by failure to observe specified or other common safety precautions or failure to exercise ordinary caution, common sense, and due care required in installing and operating the thermostat even though not specified herein.

The alert message shown here appears throughout this manual to indicate those situations and times when special care is necessary to prevent equipment damage or personal injury.



**CAUTION:** This indicates that there *could* be the possibility of equipment damage or personal injury.



**CAUTION:** If this equipment is used in a manner not specified by Bay Controls, LLC., there may be a risk of equipment damage, serious personal injury, or death.

### ***Labels***

The following safety labels alerts the installer or operator to possible hazards and serves to remind the user of specific safety precautions. Before installing and/or operating this thermostat, be certain to review the pertinent safety labels.



**CAUTION:** Read owner's manual before installing or operating. Do not remove the cover. No user serviceable parts inside.



**CAUTION:** High – Voltage Disconnect power before servicing.



**Line Power** 120 VAC, 0.25 A

### ***Limited Warranty***

Subject to the limitations contained below, and except as otherwise expressly provided herein, Seller warrants to the Buyer that all tangible articles supplied by Seller or services provided by Seller will be free of defects in materials or workmanship under normal use and care until the expiration of the applicable warranty period. Goods are warranted for five (5) years from the date of purchase. If Buyer discovers any defects and notifies Seller thereof in writing during the applicable warranty period, Seller shall at its option promptly correct, repair, or replace F.O.B. point of manufacture that portion of the good found by Seller to be defective, or refund the purchase price of the defective portion of the goods/services. All replacements or repairs necessitated by inadequate maintenance, normal wear and usage, unsuitable power sources, unsuitable environmental conditions, accident, misuse, improper installation, modification, repair, storage or handling, or any other cause not the fault of Seller are not covered by this limited warranty, and shall be at Buyer's expense. Seller shall not be obligated to pay any costs or charges incurred by Buyer except as may be agreed upon in writing in advance by an authorized Seller representative. Goods repaired and parts replaced during the warranty period shall be in warranty for the remainder of the original warranty period or ninety (90) days, whichever is longer.

THERE ARE NO REPRESENTATIONS OR WARRANTIES OF ANY KIND, EXPRESS OR IMPLIED, AS TO MERCHANTABILITY, FITNESS FOR PARTICULAR PURPOSE, OR ANY OTHER MATTER WITH RESPECT TO ANY GOODS OR SERVICES.

### ***Limitation on Liability***

THE SOLE AND EXCLUSIVE REMEDY FOR BREACH OF WARRANTY HEREUNDER SHALL BE LIMITED TO REPAIR, CORRECTION, REPLACEMENT OR REFUND OF PURCHASE PRICE AS PROVIDED UNDER THE FOREGOING LIMITED WARRANTY. IN NO EVENT, REGARDLESS OF THE FORM OF THE CLAIM OR CAUSE OF ACTION (WHETHER BASED IN CONTRACT, INFRINGEMENT, NEGLIGENCE, STRICT LIABILITY, TORT OR OTHERWISE), SHALL SELLER'S LIABILITY TO BUYER AND/OR ITS CUSTOMERS EXCEED THE PRICE TO THE BUYER OF THE SPECIFIC GOODS SUPPLIED OR SERVICES PROVIDED BY SELLER GIVING RISE TO THE CLAIM OR CAUSE OF ACTION.

BUYER AGREES THAT IN NO EVENT SHALL SELLER'S LIABILITY TO BUYER AND/OR ITS CUSTOMERS INCLUDE "CONSEQUENTIAL DAMAGES". FOR THIS PURPOSE, "CONSEQUENTIAL DAMAGES" SHALL INCLUDE, BUT NOT BE LIMITED TO, LOSS OF ANTICIPATED PROFITS, LOSS OF USE, LOSS OF REVENUE AND LOSS OF CAPITAL.

### ***Unauthorized Repair***

In the event that the owner allows the Web Thermostat to be serviced or repaired by unauthorized personnel, the coverage of the original warranty policy will be automatically terminated.

# Installation

## Overview

Installing the thermostat is a relatively simple process and typically takes from 10 to 30 minutes to complete. You should consider the current outdoor temperature. If unexpected problems occur, you do not want to risk freezing or overheating, while you are sorting the problem out.

You will need screwdrivers, a wire stripper/cutter, and a drill for installing the wall anchors to complete the installation. A volt/ohm meter can be helpful for troubleshooting but is not required.

Most conventional thermostats, probably including the one you are replacing, use a single wall mounted enclosure. The BAYweb thermostat uses two modules: the Thermostat Keypad and the Control Module. This design eliminates the use of batteries and potential need to pull new wire out to the wall, and results in a more compact and elegant design.



The Thermostat Keypad is mounted on wall in place of your existing thermostat.

If your existing thermostat is larger than the new one, you can easily pull off the keypad later to touch up the paint after you have completed the installation.

The control module mounts near or on your furnace and/or air conditioner, and is spliced into your existing thermostat wire.

The module should ideally be powered from an outlet on the same circuit as your furnace.

You will need an Internet connection for the Control Module.

If it is not convenient to plug into your network there, consider using an optional power-line Ethernet adapter.

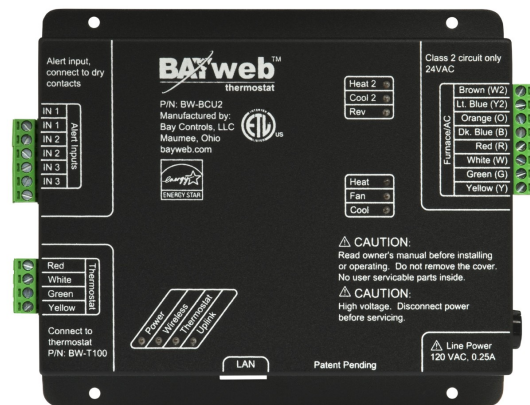

Your existing installation is should be similar to this depiction.

You have a single thermostat cable going between your wall mounted thermostat and the furnace.

The cable contains from 2 to 5 wires of different colors.

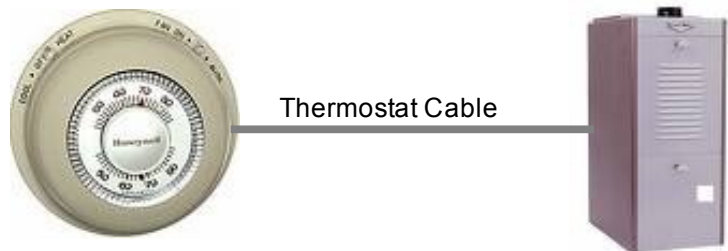

Your BAYweb Thermostat installation is shown below. The Control Module is mounted near the furnace or air conditioner and is wired into the existing thermostat cable. The control module is powered from a standard outlet.



The specific installation steps to replace your existing thermostat with the new BAYweb Thermostat are shown in the remainder of the installation instructions. If you are installing the thermostat with new equipment, the process will be similar except for removal of the old equipment.



**CAUTION:** Be sure to review all of the installation steps before starting your installation.



# 1

## Identify Wiring

The objective of this step is to identify how your thermostat wiring is connected to your furnace, air conditioner, or heat pump. This will also determine what type of control scheme your system uses.

A) Turn off all power to your furnace, air conditioner, or heat pump.



**CAUTION:** Verify that all power has been turned off. Failure to turn power off may result in personal injury, electric shock, and equipment damage.

B) Go to your existing thermostat and remove the cover or remove it from the wall as needed so you can see the terminals where the wiring is attached.

C) Note what connections your system uses and verify that your thermostat is using the correct terminals with the correct wire color as shown in the table below.

If your installation is using non standard wire colors, you will have to note what color is being used for what terminal and match your wire colors to the appropriate terminal.

Note that if you have a wire connected to terminal “C” or “X”, it will not be used for your BAYweb Thermostat installation.

Terminal	Function	Standard Wire Color	My Wire Color	Connected (Y/N) ?
R, Rh, or Rc	24 VAC Supply	Red		
W or W1 or Aux	Heat or Aux Heat	White		
G	Fan	Green		
Y or Y1	Cool	Yellow		
W2	2 <sup>nd</sup> Stage Heat	Brown		
Y2	2 <sup>nd</sup> Stage Cool	Light Blue		
O	Reversing Valve	Orange		
B	Reversing Valve	Dark Blue		
E	Emergency Heat	Varies		
C or X	24 VAC Return	Blue or Black	NOT USED	

D) The following table shows what terminals are used by the different control methods. Determine which control method your system is using by matching which terminals are connected to your wiring.

Circle the number of the system type that you have. You will use this information when configuring your thermostat in Step 5.

If you have a wire connected to terminal “E”, you have a heat pump with an emergency heat function. If you do not also have a wire connected to terminal “W” you will need to connect the wire connected to “E” to terminal “W”.

#	System Type	Terminals				
		W or W1 or Aux	Y	W2	Y2	O or B
1	Conventional Heat Only*	Y				
2	Conventional Cool Only*		Y			
3	Conventional One Heat/One Cool	Y	Y			
4	Conventional Two Heat/One Cool	Y	Y	Y		
5	Conventional Two Heat/Two Cool	Y	Y	Y	Y	
6	Conventional One Heat/Two Cool	Y	Y		Y	
7	Heat Pump One Heat/One Cool		Y			Y
8	Heat Pump Two Heat/One Cool	Y	Y			Y
9	Heat Pump Two Heat/Two Cool		Y		Y	Y
10	Heat Pump Three Heat/Two Cool	Y	Y		Y	Y

E) If you have any question on what system type you have, contact support ([support@bayweb.com](mailto:support@bayweb.com)) or contact your local HVAC service company.

\* NOTE: The BAYweb Thermostat requires at least 4 wires in the thermostat cable between the Thermostat keypad and the Control Module. If you have a heat or cool only system that only has 2 wires, you will need to install new thermostat wire. It is less desirable, but often possible to obtain satisfactory operation using 3 wires. Consult the Frequently Asked Questions section at [www.bayweb.com](http://www.bayweb.com) for more information.

# 2

## *Install Control Module*

- A) Find your thermostat cable where it goes into the furnace, air conditioner, or heat pump. This is the same cable identified in Step 1 and should be the same color and thickness as that cable.



**CAUTION:** There may be other cables of similar color connecting other devices such as a humidifier. Be sure to use the cable that runs back to your thermostat and not one that is connected to another device. Connecting the Web Thermostat to the wrong cable can result in electric shock and/or equipment damage.

- B) Mount the Control Module using the following criteria:

- Select a location near the furnace where there is sufficient room to mount the Control Module along where the thermostat cable runs. The thermostat cable will need to reach both the “Thermostat” and “Furnace/AC” terminals of the Control Module.
- Select a location within 6 feet of a power outlet, ideally on the same circuit as the furnace/AC, or heat pump.
- Select a location where you can connect to the Internet. If wiring is not convenient, we suggest using a power line Ethernet adapter that will allow you to make this connection using your existing power wiring.

- C) Prepare the thermostat cable:

With the furnace, air conditioner, or heat pump power OFF, cut the thermostat wire at a point where both ends will be able to reach the Control Module mounting location.

Using a wire-stripping tool, strip approximately 2 inches of the outer jacket off both ends of the thermostat cable, then strip approximately ¼ inch off the end of each of the thermostat wires.

- D) Connect the wiring going to the Thermostat Keypad:

Attach the wires in the cable coming from the thermostat to the terminals on the **LEFT** side of the control module into the connector labeled **"Thermostat"**. Be sure to match the wire color and terminal designation as identified in Step 1. If you have more wires than the four wires labeled on the connector (Red, White, Green, Yellow), bend them back out of the way and tape to the cable. They will not be used.

Note that you need four wires between the Control Module and Thermostat Keypad even if you have a heat or cool only system.

E) Connect the wiring going to the furnace, air conditioner, or heat pump:

Attach the wires in the cable coming from the furnace to the terminals on the **RIGHT** side of the control module labeled "**Furnace/AC**". Be sure to match the wire color and terminal designation as identified in Step 1.



**CAUTION:** It is very important to connect the thermostat cable to the correct connectors on the Control Module. Failure to do so may cause equipment damage.

F) Confirm that the terminal screws are tight, the wires will not pull out of the terminals, and that there are not any shorts between terminals.



The Control Module is mounted near the furnace where the thermostat cable is routed.

This location should be within 6 feet of a power outlet.

You will connect the module to your network using standard Ethernet cable, or using the power line Ethernet adapters.

Orient the Control Module so the Furnace/AC connector is on the side that goes to the furnace, mounting it "upside down" if needed.

The Control Module installed and wired to your furnace, air conditioner, or heat pump.

**Do not** plug in the Control Module power or Internet yet. This will be done in step 4.



# 3

## ***Install Thermostat Keypad***

- A) Remove the wires from your existing thermostat, taking care that the wires do not fall back into the wall.
- B) Remove the existing thermostat and any associated mounting hardware.
- C) Fill in any holes from the previous thermostat mounting and paint the wall if needed.
- D) Hold the Thermostat Keypad in the desired position and mark the location of the top mounting screw. Locate the bottom mounting screw 3 ½ inches below the top screw location. Drill 3/16 inch holes and install the supplied wall anchors. Tap the anchors with the screwdriver handle to insure that they are flush or slightly indented into the wall.
- E) Screw the supplied mounting screws into the wall anchors leaving about 1/16<sup>th</sup> inch gap for the Thermostat Keypad to slide over.
- F) Make sure the ends of each wire are stripped and ready to be attached to the new Thermostat Keypad. If any wires break off then use your wire stripper to strip approximately ¼ inch of insulation from the end of the wire.
- G) Using the supplied wire nuts, attach the four colored wires coming from the Thermostat Keypad (red, white, green, yellow) to the four matching colored wires from the cable in the wall. If your installation uses non standard wire colors, use the table you completed in step 1C to connect your wire colors to the standard color of the Thermostat Keypad.
- H) If you have any spare wires not being used, cut off any bare sections and insure that they will not short to anything in the Thermostat Keypad.
- I) Push the thermostat cable into the wall to remove as much slack as possible. Fit the any excess wiring into the space behind the Thermostat Keypad.
- J) Attach the Thermostat Keypad to the wall by sliding the slot at the top and key opening at the bottom over the anchor screws installed in step 3D above. The sideways key slot will allow some side to side adjustment to facilitate vertical alignment.
- K) Check the fit to the wall. The Thermostat Keypad should have a tight fit to the wall. If it is too loose, screw the mounting screws in a bit further as needed to obtain a tight fit.



Wall mounting location with the existing thermostat cable prepared to install the new Thermostat Keypad.

If the ends of the existing wiring are worn or broken. Cut off the ends and strip about ¼ inch of insulation from the end of each wire.

Now is a good time to touch up the paint if needed.

Locate and install the wall anchors and mounting screws as shown, and described above.

Connect the Thermostat Keypad to your thermostat wiring as shown.

Route the slack in the thermostat cable and wiring back into the wall.

Keep the wire connectors (wire nuts) on the outside of the wall. They will fit inside the Thermostat Keypad when attached to the wall.

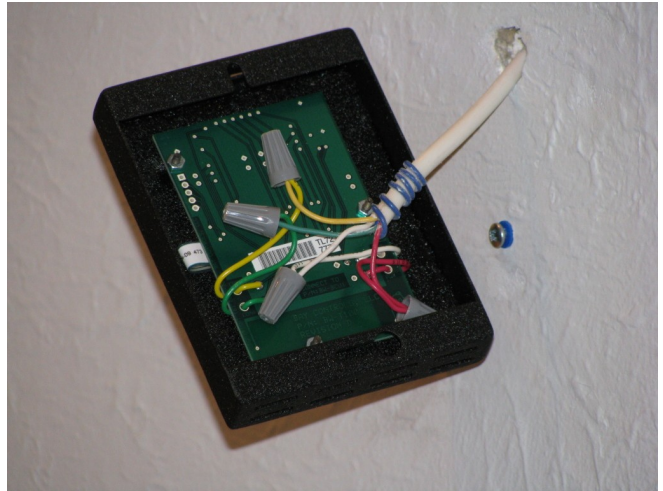

Complete installation of the Thermostat Keypad by sliding it over the anchor screws.

Be careful to not pinch or bunch up the wiring behind the module.

Adjust the anchor screws as needed to obtain a tight fit flush to the wall.

# 4

## Connect to the Internet

The BAYweb Thermostat is factory configured for system type 3, conventional one heat/one cool. This will also work for system types 1 and 2. If you have a multistage furnace, air conditioner, or heat pump, you will need to connect the thermostat to the Internet and configure it for the type of system that you have prior to use.

- A) Connect the Control Module to the Internet. Plug one end of an Ethernet cable into the LAN port on the bottom of the Control Module and the other end into a port on a router or switch on your home network.

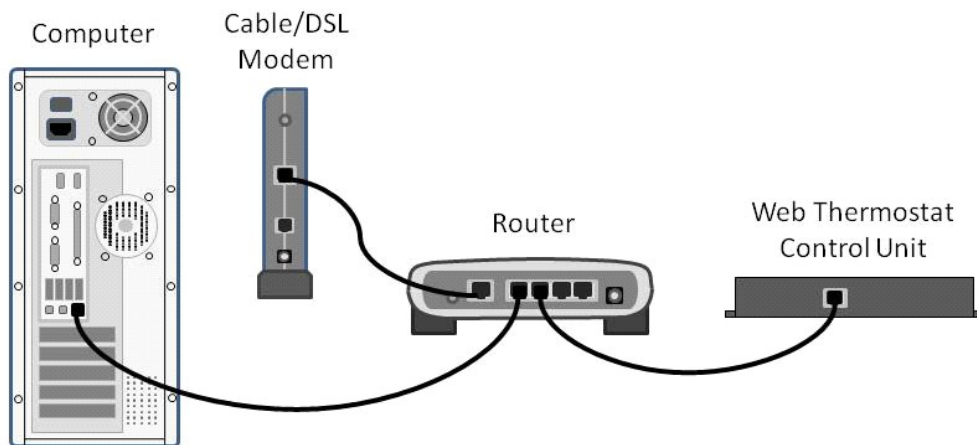

- B) If direct wiring is not convenient, use Power line Ethernet adapters. Plug one adapter into a power plug near the control module, and the other adapter near your home router. Then just plug the Ethernet cables into the adapters and the ports.
- C) The BAYweb Thermostat does not require any configuration or programming of your networking equipment. You do not need to change security settings. Just plug it in and you are all set to go.
- D) Plug in the control module. Do not power up your furnace, air conditioner, or heat pump yet. The Power LED on the control module should illuminate.



**CAUTION:** To reduce the risk of electric shock, this product has a grounding type plug that has a third (grounding) pin. This plug will only fit into a grounding type power outlet. If the plug does not fit into the outlet, contact a qualified electrician to install the proper outlet. Do not change the plug in any way.

- E) In less than a minute the “Uplink” light should illuminate on the control module. If you do not see “Uplink” light up within a couple of minutes, refer to the Troubleshooting section of this manual.

# 5

## *Configure the Thermostat*

The thermostat is configured using the BAYweb portal. The following steps will guide you through setting up your own personal web portal and configuring the thermostat. If you have already setup your own portal, simply click on the “My Devices” link to add the thermostat.

- A) Go to the BAYweb site by entering [www.bayweb.com](http://www.bayweb.com) in the address bar of your web browser.
- B) Click on the “Create an account” link in the login box.
- C) Enter the requested information.
- D) You will be sent an email to confirm you have entered a valid email address and validate your identity with the given email. You must follow the instructions in the email to activate your account.
- E) Once your account has been activated, login to your personal web portal at [www.bayweb.com](http://www.bayweb.com) using your user ID and password.
- F) After logging in, click on the “My Devices” link on the top right of the page.
- G) Click the “Add” button on the My Devices page.
- H) Enter the serial number and key code that are printed on the cover of this manual, and can also be found on a label on the Control Module.
- I) When prompted for the “System Type”, enter the type you determined in installation step 1D. Once this is complete, the thermostat is configured for your specific equipment.



# 6

## *Test Operation*

- A) Turn the power back on to the furnace, air conditioner, or heat pump.
- B) Verify that the “Power” and “Thermostat” lights are illuminated on the control module. If either one is not on, refer to the Troubleshooting section of this manual.
- C) Verify that the Thermostat Keypad is showing the temperature. If it is showing an “E” with a number, this is an error code. Refer to the Troubleshooting section.
- D) Test FAN operation: Press the keypad near the “FAN” label. An LED should illuminate next to the label and the fan should be running. Press FAN again and the fan will turn off. If the fan did not operate, consult the Troubleshooting section of this manual.
- E) Test HEAT operation: Select heat mode by pressing the keypad near the HEAT label, an LED should illuminate next to the label. Press the up arrow on the keypad to raise the set point to at least 2 degrees above the current temperature.

Check your furnace or heat pump and confirm that it is heating. Note that your fan will not run until your furnace has heated up. This may take a few minutes.

Note that once the heat turns on, it will remain on for a minimum of 1 minute and once it turns off, it will remain off for 1 minute as well.

If operating correctly, go back to the keypad and change the set point back to a normal level. If heating did not function, refer to the Troubleshooting section.

- F) Test COOL operation:



**CAUTION:** If the outdoor temperature is below 40° F you should not run your air conditioner as that may result in equipment damage.

Select cool mode by pressing the keypad near the COOL label. An LED should illuminate next to the label. Press the down arrow on the keypad to lower the set point to at least 2 degrees below the current temperature.

Check your air conditioner or heat pump and confirm that it is running.

- G) If operating correctly, go back to the keypad and change the set point back to a normal level. If cooling did not function, refer to the Troubleshooting section.

# Operation

## ***Using the Thermostat Keypad***

The Thermostat Keypad shows the current temperature, set point and modes, and allows you to manually control your furnace and air conditioner.

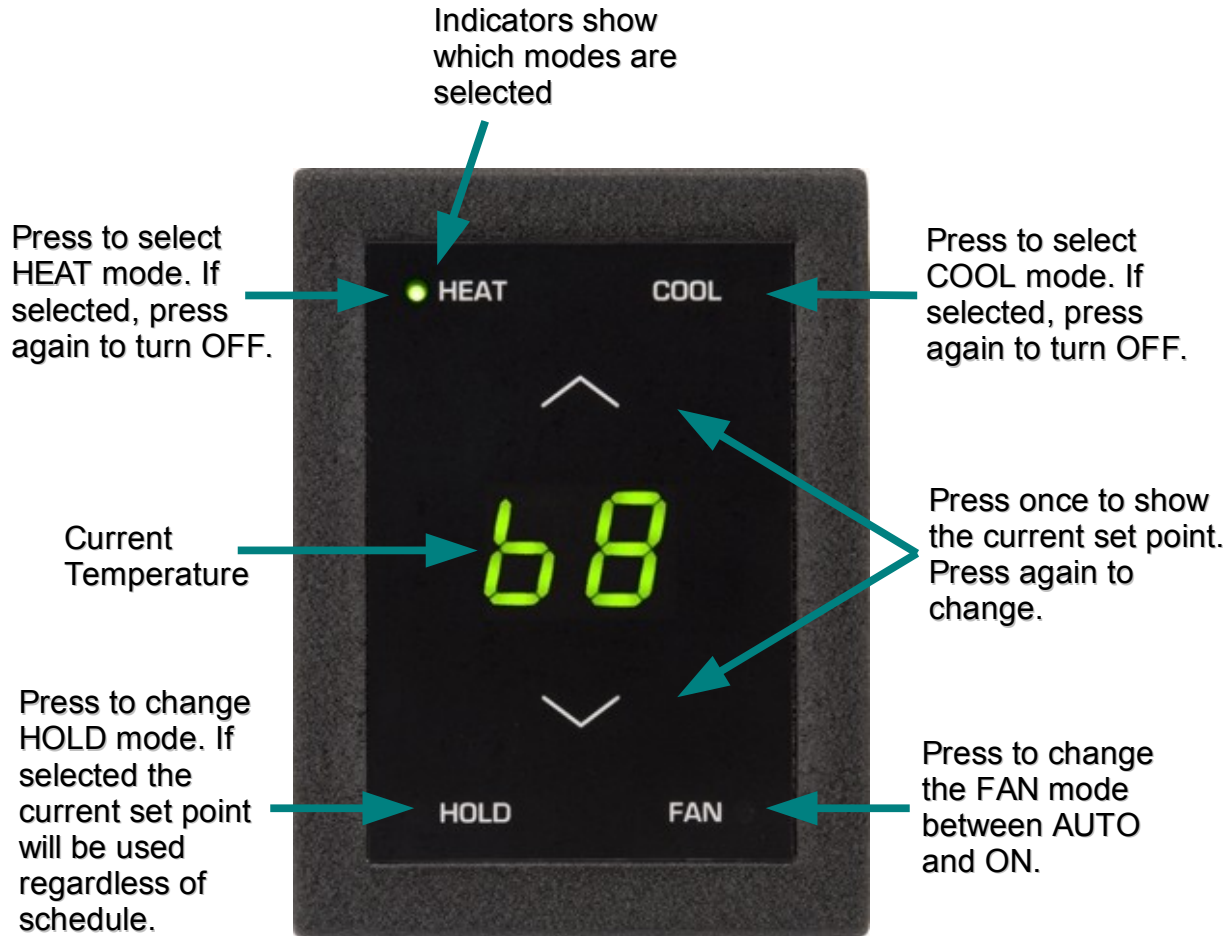

## ***Using the Web Portal***

The real power of the BAYweb Thermostat is realized by using the BAYweb Portal to access your thermostat. This portal can be accessed anytime from anywhere via web browser and Internet enabled mobile phone. Unlimited use of the portal is included at no charge.

If you have not already done so, setup your personalized portal by going to the web site [www.bayweb.com](http://www.bayweb.com), register a new account, login and add a device (your thermostat). You will need the serial number and key code that are on the front of this manual.

## ***Using Your Mobile Phone***

Once you have setup your personalized web portal, you can also use most any mobile phone that has web access to remotely access your thermostat and other web devices. To access the mobile web portal, enter the following address in your mobile phone browser:  
[www.bayweb.com/mobile](http://www.bayweb.com/mobile).

## ***Occupancy Sensing***

The BAYweb Thermostat can use various types of sensors (motion sensors being the most common) which allow the thermostat to “know” when you are home (Occupied) or when you are away (Not Occupied).

Occupancy sensors enable the Web Thermostat to operate as one of the most efficient thermostat available today. Using occupancy sensors will save you the most amount of money and simplify setting up your thermostat.

Using Occupancy Sensing allows you to only pay for heating or air conditioning to your comfort level when you are there. Imagine running out to go shopping on a weekend and being gone from your house for say 5 hours. Do you always turn your thermostat down when you go shopping? Now your BAYweb Thermostat can do it for you.

Use of Occupancy Sensing simplifies setting up your thermostat’s schedule because all you need to do is determine when you generally are asleep and when you generally wake up (if you want your house heated before you wake). The remainder of the time you can tell the thermostat to sense if you are there or not.

While “**Sensing**”, the thermostat will automatically set back the temperature to your “**Away**” set point after a period of time of not sensing occupancy. Likewise, upon sensing occupancy, it will switch to your “**Home**” set point.

Scheduling a “**Sleep**” activity disables Occupancy Sensing to prevent switching to the Home set point if you get up in the middle of the night and happen to pass a sensor.

## ***Implementing Occupancy Sensing***

To enable and use occupancy sensing you need to install one or more occupancy sensors and configure the thermostat to use them on the web portal.

The thermostat can use wireless (X10 wireless protocol) or wired occupancy sensors. Bay sells a low cost wireless occupancy sensor that is ready to use with the BAYweb Thermostat. Just put in a couple of batteries and mount it in a location that typically sees activity when you are home. You can use as many sensors as needed enabling the thermostat to monitor multiple locations in your home for occupancy.

Wired occupancy sensors can use either normally open or closed contacts. Motion sensors from most alarm systems are compatible with the BAYweb thermostat.

Occupancy sensing with pets in the home is accomplished by masking off the lower part of the sensing lens.

You should locate your sensors in high-traffic areas of your house so that they will be most likely to sense when people are present. The sensors from Bay have a 10+ foot range and will sense people as they pass in front of the sensor. We have found that locating them at about chest height or higher works well.

Once you have installed your occupancy sensors login to the web portal to enable them. To enable occupancy sensing select the “Schedule” page from the thermostat applet menu and set the “Occupancy Inactivity Time”. We suggest using 1 hour for this interval initially, you can adjust this value later if needed to suit your lifestyle.

If you are using sensors not supplied by Bay, you may need to configure the thermostat to look for other wireless IDs or to monitor the wired input. This is done on the “Settings” page of the thermostat applet.

After enabling occupancy sensing review your schedule and set your “Sensing”, “Sleep”, and “Home” times as described above. Your thermostat will now automatically adapt your HVAC operation to match your lifestyle.

## **Testing Occupancy Sensing**

If you want to see if the sensors are working as expected, login to the web portal and select “Sensor Log” from the thermostat applet menu.

The thermostat applet “Operation Log” will give a detailed view of occupancy sensing operation.

## **Occupancy Sensing with Multiple Thermostats**

If you are using multiple BAYweb thermostats in the same building, and wish to have each thermostat sense occupancy (using wireless sensors) in separate areas, you will need to configure the occupancy sensors with different X10 device IDs.

The default X10 ID of Bay supplied sensors is “A1”. Note that these sensors also use an ID that is one more than what is configured (default “A2”) for other purposes, do not use the next ID for occupancy sensing. For example, acceptable IDs would be A1, A3, A5...

Refer to the instructions provided with the sensor for detail on how to change the sensor's X10 ID. Configure the thermostat to look for the alternate X10 IDs on the “Settings” page of the thermostat applet.

## **Alerting**

Alerting is a powerful feature that enables you, and others you designate, to be notified of the following events:

- Problems with your thermostat and HVAC system.
- Excessive heating or cooling energy usage.
- Intrusion.
- Loss of Internet connectivity.
- Other problems or alerts with anything else you choose to connect to the control module (wired or wireless).

Alerting provides many of the features of a traditional alarm system without the monthly fee. If you have an alarm system that is no longer in use, you can wire those sensors into the control module to convert your old system to a self-monitored system.

When the BAYweb Thermostat senses an alert condition it immediately sends a message to the BAYweb portal servers, which in turn emails the alert message to the list of recipients you may specify. Typically you will enter an email address that will deliver the alert message to your mobile phone via text messaging (SMS).

The time it takes for you to receive an alert varies mostly due to the variable delivery time of text messaging. The BAYweb alert server will normally dispatch the alert email within 10 seconds of the event.

## **Implementing Alerting**

There is a wide variety of additional sensors and devices that can be integrated into the alerting system. Refer to the device instructions for detail on integrating those devices.

To enable alerting, login to the web portal, bring up the “Settings” page in the thermostat applet, and set the “Alert email” to the addresses you want the notification to go to. Set “Alert Interval” to something other than “Disabled”.

Depending on any other sensors or devices you have connected to the control module, you may need to configure the thermostat to look for other X10 wireless IDs and wired inputs. This is also done from the “Settings” page of the thermostat applet.

## **Testing Alerting**

To verify that alerting is operating as expected, login to the web portal and review the thermostat applet “Operation Log”, “Alert Log”, and “Sensor Log”.

## Reference

### *Thermostat Keypad*



The Thermostat Keypad module senses the current temperature and provides an interface for manual control.

Normally the displayed number (68 in this case) indicates the current temperature.

To change the set point, press the up or down arrows. The display will switch to the current set point. Note that a decimal point is displayed while showing the set point. The display will automatically revert to the current temperature after a few seconds if no keys are pressed.

The display will show “LO” to indicate locked if a key is pressed when the keypad has been locked (using the web portal).

#### **HEAT**

The indicator is illuminated when the thermostat is in heat mode. The key is used to select heat mode or turn the furnace off.

#### **COOL**

The indicator is illuminated when the thermostat is in cool mode. The key is used to select cool mode or turn the air conditioner off.

#### **HOLD**

The indicator is illuminated when the thermostat is in hold mode. The key is used to select or cancel hold mode. When in hold mode, the current set point will be used regardless of what is scheduled. Note that the web and mobile portals can still override this setting.

#### **FAN**

The indicator is illuminated when the fan is running manually. The key is used to manually turn the fan ON, or set it in automatic.

### **Error Codes**

The thermostat may display an error code to alert you of problems. When an error code is displayed the temperature is replaced with “E#”, where the number represents an error described below. To clear the error code, press any key on the keypad. Refer to the Troubleshooting section for corrective action.

Code	Meaning
E1	Indicates that the thermostat keypad is not communicating with the control module. The thermostat can not control the furnace/AC in this condition
E2	Indicates that the temperature sensor in the keypad module has failed
E3	Indicates that DHCP (Dynamic Host Configuration Protocol) is not functioning on your home network
E4	Indicates that the control module has lost communication with the BAYweb portal
E5	Indicates that the non-volatile memory was corrupted or lost

## Control Module

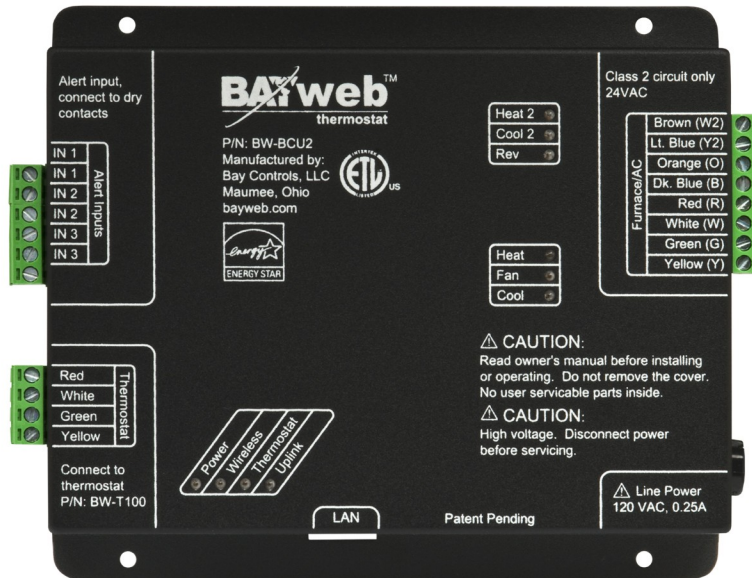

## Alert Inputs

There are three inputs that can be used to connect to a variety of wired sensors, such as a sump pump monitor or alarm door contacts.

To use this feature, wire the dry contacts of a sensor or switch to the terminals of one of the inputs. The two terminals labeled IN1 are for alert input 1, IN2 for alert input 2, and IN3 for alert input 3.

The Settings page on the Web Portal is used to assign the inputs to a zone, and configure normally open or normally closed contacts.



**CAUTION:** Do not connect an Alert input to any external voltage source. Dry contacts only. Failure to do so may cause equipment damage.

## Thermostat Connector

This connector is used to connect the Thermostat Keypad module to the Control Module. This

is a proprietary interface and can only be used with the specified modules. The Red and White terminals supply power (3.3 VDC), the Green and Yellow terminals utilize a proprietary communications protocol.

## Furnace/AC Connector

This connector is wired to your furnace and/or air conditioner, or heat pump, and provides control of your equipment. Refer to the Thermostat Connections section of this manual for detail of terminal usage.

## LAN Port

The LAN port is a standard Ethernet interface (IEEE 802.3 compatible with 10/100/1000 Base-T networks). This port operates at 10 Mbps (10Base-T). There are 2 LED activity indicators built into the the connector. The green LED will be illuminated whenever there is a physical link to your network (plugged in). The amber LED is illuminated when there is activity on the port.

## Line Power

The line cord is used to power the thermostat. This is a standard 3 blade grounded plug. Ideally this should be powered from the same circuit as your furnace/AC.



**CAUTION:** To reduce the risk of electric shock, this product has a grounding type plug that has a third (grounding) pin. This plug will only fit into a grounding type power outlet. If the plug does not fit into the outlet, contact a qualified electrician to install the proper outlet. Do not change the plug in any way.

## Status Indicators

Indicator	Description
Heat	For conventional systems, this LED indicates when the thermostat is signaling the furnace to produce stage one heat. For heat pump systems, this LED indicates when the thermostat is activating auxiliary heat.
Fan	Indicates when the thermostat is signaling the furnace, air conditioner, or heat pump to turn on the fan.
Cool / Comp	For conventional systems, this LED indicates when the thermostat is signaling the air conditioner to operate stage one cool. For heat pump systems, this LED indicates when the thermostat is signaling the heat pump to run the stage one compressor.
Power	Indicates that there is power supplied to the control module from the line cord.
Wireless	Illuminates for 2 seconds whenever an X10 wireless signal is received for any configured occupancy or alert sensor.
Thermostat	Indicates that the control module is successfully communicating with the Thermostat Keypad module.



Indicator	Description
Uplink	Indicates that the control module is successfully communicating with the BAYweb portal.
Heat 2	For conventional multistage systems, this LED indicates when the thermostat is signaling the furnace to produce stage two heat. For conventional single stage and heat pump systems, this LED indicates when thermostat is signaling for the zone damper to open.
Cool 2 / Comp 2	For conventional systems, this LED indicates when the thermostat is signaling the furnace to produce stage two cool. For heat pump systems, this LED indicates when the thermostat is signaling the heat pump to run both stages of the compressor.
Rev	<p>Indicates that the thermostat is signaling the heat pump to activate the reversing valve. The “B” terminal is normally closed, it supplies power when the Rev LED is off. The “O” terminal is normally open, it supplies power when the Rev LED is illuminated.</p> <p>The use of the “O” and “B” terminals may vary by manufacturer of the heat pump. Typically, the “O” terminal supplies power to signal for cooling, and the “B” terminal supplies power to signal for heat. If your system appears to be operating opposite of what it should, move the reversing valve wire to the other terminal.</p>

## ***Troubleshooting***

We encourage you to communicate any problems you have encountered to us, even if you are able to solve them on your own. We would also like to have any suggestions or comments about the installation procedure.

The preferred method of communicating with us is via email. We use an automated tracking system to insure that we respond to your messages in the quickest possible time, and provide the shortest path to problem resolution. Our support email address is [support@bayweb.com](mailto:support@bayweb.com). We also have an on line support page that you can use to send a message to our support staff. If you need to speak to a support Representative, refer to the Obtaining Support section of this manual for contact information.

When contacting us for support, please provide your name, web portal user ID (if you have one), and your thermostat serial number. We may also request your key code to validate that you have a given piece of equipment. The serial number and key code are located on the front cover of this manual and on the Control Module.

We suggest you review the Solutions to Problems section and check the support resources on [www.bayweb.com](http://www.bayweb.com) which may provide you with a simple solution to the problem.

## Solutions to Problems

Problem	Solution
No Control Module power indication.	<ul style="list-style-type: none"> <li>➤ Check for power at outlet.</li> <li>➤ Unplug Alert input and Thermostat connectors, if power light comes on there is a short or improper connection on one or both of these connections.</li> <li>➤ Contact support for replacement Control Module.</li> </ul>
Keypad is dark, no power at keypad.	<ul style="list-style-type: none"> <li>➤ Check Control Module has power.</li> <li>➤ Check wiring between Keypad and Control module.</li> <li>➤ Check for power (3.3 VDC) on the red and white terminals of the Thermostat connector of the Control Module, and on the wires at the Thermostat Keypad.</li> <li>➤ Contact support for a replacement Thermostat Keypad.</li> </ul>
Fan control does not work.	<ul style="list-style-type: none"> <li>➤ Verify on the Thermostat Keypad that the Fan is selected ON.</li> <li>➤ Verify on the Control Module that the Fan light is ON.</li> <li>➤ Check the red and green wires between the Furnace/AC connector on the Control Module and your Furnace/AC.</li> <li>➤ Check that the Furnace/AC has power.</li> </ul>
Heat does not work.	<ul style="list-style-type: none"> <li>➤ Verify that Heat mode is selected on the Thermostat Keypad.</li> <li>➤ Verify that the set point is higher than the current temperature.</li> <li>➤ Verify on the Control Module that the Heat light is ON.</li> <li>➤ Check the red and white wires between the Furnace/AC connector on the Control Module and your Furnace/AC.</li> <li>➤ Check that the Furnace/AC has power.</li> </ul>

Problem	Solution
Cool does not work.	<ul style="list-style-type: none"> <li>➤ Verify that the outside temperature is greater than 40° F.</li> <li>➤ Verify that Cool mode is selected on the Thermostat Keypad.</li> <li>➤ Verify that the set point is lower than the current temperature.</li> <li>➤ Verify on the Control Module that the Cool light is ON.</li> <li>➤ Check the red and yellow wires between the Furnace/AC connector on the Control Module and your Furnace/AC.</li> <li>➤ Check that the Furnace/AC has power.</li> </ul>
<p>Thermostat Keypad shows error code “E1”:</p> <p>The Thermostat Keypad is not communicating with the Control Module.</p>	<ul style="list-style-type: none"> <li>➤ Check the wiring and connections between the Thermostat Keypad and Control module .</li> <li>➤ Try wiring the Thermostat Keypad directly to the Thermostat connector of the Control module. If this works, the problem is somewhere in the wiring.</li> <li>➤ Check the Thermostat light on the Control Module. If ON, the Control Module is receiving data from the Thermostat Keypad, the thermostat may be able to control your furnace/AC in this condition. Check the web portal.</li> <li>➤ Contact support for replacement Thermostat Keypad and Control module.</li> </ul>
<p>Thermostat Keypad shows error code “E2”:</p> <p>The temperature sensor has failed in the Keypad Module.</p>	<ul style="list-style-type: none"> <li>➤ The thermostat can not operate in this condition.</li> <li>➤ Contact support for a replacement Keypad module.</li> </ul>
<p>Thermostat Keypad shows error code “E3”:</p> <p>Your Internet router is not supplying a local address to use on your network (DHCP is inoperative).</p>	<ul style="list-style-type: none"> <li>➤ Try resetting or power cycling your Internet router.</li> </ul>
<p>Thermostat Keypad shows error code “E4”:</p> <p>The Internet connection was down for an extended period of time (It is unlikely that this is a problem with the thermostat).</p>	<ul style="list-style-type: none"> <li>➤ Check your Internet connection.</li> <li>➤ Check your Internet wiring.</li> <li>➤ Make sure you can browse the Internet using the thermostat network cable.</li> </ul>

Problem	Solution
<p>Thermostat Keypad shows error code “E5”: The non-volatile memory in the control module has been lost or corrupted.</p>	<ul style="list-style-type: none"> <li>➤ The thermostat can continue to operate.</li> <li>➤ Contact support to obtain a replacement Control Module.</li> </ul>
<p>Thermostat Keypad shows “LO”: The keypad has been locked.</p>	<ul style="list-style-type: none"> <li>➤ Login to the web portal to unlock.</li> <li>➤ In an emergency, and if no Internet connection is available, cycle the power to your thermostat to unlock.</li> </ul>
<p>Thermostat not responding to the schedule at the correct time.</p>	<ul style="list-style-type: none"> <li>➤ Review the Settings page on the Thermostat applet and make sure the timezone is set correctly.</li> </ul>
<p>Wireless occupancy sensor not working.</p>	<ul style="list-style-type: none"> <li>➤ Verify the X10 ID settings – see the settings page on the thermostat applet.</li> <li>➤ Verify the X10 ID settings of the sensor, refer to the instructions provided with the sensor.</li> <li>➤ Check that the Wireless light on the Control Module turns ON when the sensor is activated.</li> <li>➤ Try adjusting/moving the antenna wire.</li> </ul>
<p>Wired alert input not working.</p>	<ul style="list-style-type: none"> <li>➤ Verify the wired input settings – see the Settings page on the thermostat applet.</li> </ul>
<p>Control module not connecting to Internet, Uplink light does not come on.</p>	<ul style="list-style-type: none"> <li>➤ Verify that the green LED on the LAN connector (on the side of the Control Module) is illuminated.</li> <li>➤ Verify that the amber LED on the LAN connector is blinking.</li> <li>➤ Plug a laptop or PC into the connection you are using for the thermostat and verify that you can browse the Internet.</li> </ul>
<p>Heat or Cool does not turn off.</p>	<ul style="list-style-type: none"> <li>➤ The Heat or Cool outputs will stay on for a minimum time period (default of 1 minute). See the Schedule page on the thermostat applet for the current <b>cycle rate</b>.</li> </ul>

## Obtaining Support

Customer support is handled **on line** 24 hours per day, 7 days a week. Before requesting support, please review the Frequently Asked Questions and other resources available at [www.bayweb.com](http://www.bayweb.com). When contacting us for support, please provide your name, web portal user ID (if you have one), and thermostat serial number, located on the front cover of this manual and on the Control Module.

Support email: [support@bayweb.com](mailto:support@bayweb.com)

### Bay Controls, LLC

6528 Weatherfield Ct

Maumee, OH 43537

419-891-4390 (Monday - Friday 8:00 AM – 5:00 PM EST)

## Zone Control

This model of the BAYweb Thermostat can be used with conventional single stage and heat pump based zoned systems, a damper control signal is provided on terminal W2. Note that this terminal is also used for second stage heat on conventional multistage furnaces.

Zone control installations are beyond the scope of this manual. Refer to the appropriate BAYweb Application Note, available at [www.bayweb.com](http://www.bayweb.com) for more information.

## Thermostat Connections

The following table shows all standard thermostat terminals and associated functions.

Terminal	Function	Standard Wire Color
R, Rh, or Rc	24 VAC Supply (Hot)	Red
W or W1	Heat	White
G	Fan	Green
Y or Y1	Cool	Yellow
C or X	24 VAC Common (Return)	Blue
W2	Stage 2 Heat	Pink or other color
Y2	Stage 2 Cool	Blue or Pink
O or O/B	Reversing Valve (Heat Pump)	Orange, Blue, or Black
E	Emergency Heat (Heat Pump)	Blue, Pink, Gray or Tan

### ***Thermostat Wiring***

If you need to replace your thermostat wiring, or are installing wiring for new equipment, the following wire specification must be followed to maintain the safety ratings of UL 873:

18 AWG 4, 5, or 7 Conductor 300V, Type CL2 (UL) 105 Deg C.

### ***Control Module Terminals***

Required by UL 873: the connector manufacturer specifies the connector terminal screws should be torqued to 4.43 in-lbs (0.5 Nm).

## Specifications

Part Numbers:	BW-WT2-[COLOR] Thermostat Keypad: BW-T100-[COLOR] Control Module: BW-BCU2
Applications:	Residential, commercial
System Types:	Gas, oil, or electric heat with air conditioning
Control Types:	Single and multistage heat/cool, heat pump with aux heat
Fan Control:	Auto, On, auto with minimum circulation
Set Points:	4 heat, 4 cool
Schedule:	7 day, up to 48 periods per day, automatically adapts with occupancy sensing
Control Features:	Automatic changeover, compressor protection, set point limiting
User Interface:	Keypad with LED display and Web-based
Clock:	Synchronized with NIST atomic clock ( $\pm 1$ sec)
Memory:	All settings and data maintained in non-volatile memory indefinitely
Occupancy/Alert Inputs:	Unlimited X10 wireless and (1) wired dry contact input
Control Temperature Range:	35° to 99° F
Control Response:	$\pm 1^\circ$ F
Accuracy:	1° F
Cycle Rates (at 50% Load):	Heat and cool selectable 2 – 30 cycles per hour
Shipping Temperature Range:	-40° to 150° F
Operating Temperature Range:	0° to 120° F
Operating Relative Humidity:	5% to 90% (non-condensing)
Power Method:	Independently powered, line cord
Power Requirements:	120 VAC, 60 Hz, 0.25 Amp maximum
Control Electrical Rating:	Class 2, 20 – 30 VAC 3.2 Amp maximum
Dimensions:	Keypad: 3" W x 4" H x 0.6" D Control Module: 6.85" W x 5.85" H x 1.3" D
Weight:	Keypad: 4 oz Control Module: 8 oz
Agency Approvals:	Energy Star, ETL Listed (UL 873), NEMA DC-3