

W8600F Air Cleaner Monitor

INSTALLATION INSTRUCTIONS

APPLICATION

The W8600F Air Cleaner Monitor is an option available for use with the F50F and F52F Honeywell Electronic Air Cleaners (EAC). The series two F50F and F52F require a solid state power supply that is compatible with the W8600F driver board. Any series one F50E, F or F52F can be upgraded to use the W8600F when the power supply is replaced and the driver board (included in W8600F kit) is installed.

The W8600F function indicator panel has four liquid crystal display (LCD) arrowheads that point to ON, BATTERY, SERVICE or FAULT. See Fig. 1. The arrowheads darken to indicate the existing EAC condition. See Table 1.

INSTALLATION

When Installing this Product.

1. Read these instructions carefully. Failure to follow the instructions could damage the product or cause a hazardous condition.
2. Check the ratings given in the instructions and on the product to make sure the product is suitable for your application
3. Installer must be a trained, experienced service technician.
4. After completing the installation, use these instructions to check out the product operation.

Location

The styling of the W8600F is designed to blend with the latest T8600 family of Honeywell Chronotherm® IV Deluxe Programmable Thermostats. A special mounting template is included for mounting next to the T8600. The W8600F can also be mounted at any other convenient location in the living area or equipment room. See Fig. 2.

NOTE: The W8600F shares no common electrical connections with the thermostat.

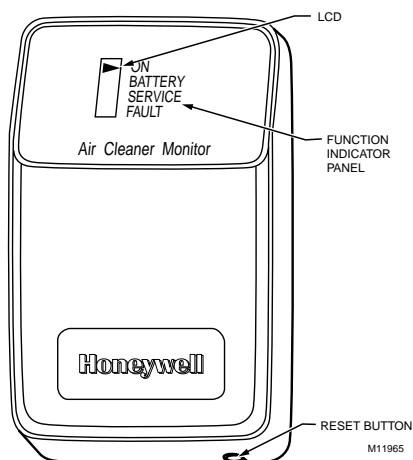

Fig. 1. W8600F Air Cleaner Monitor features.

Table 1. Description of W8600F Function Indicator Panel.

| Indicators | Condition |
|------------|---|
| ON | EAC is powered and system blower is running. |
| BATTERY | Battery that maintains W8600F memory is low and needs to be replaced. |
| SERVICE | EAC prefilter and cells need to be washed ^a . |
| FAULT | <ul style="list-style-type: none"> • Shorting of collector plates. • Continuous ionizer or collector plate arcing. • Power supply failure. • Excessive current. • Major reduction in high voltage. • EAC prefilter and cells are past SERVICE level of dirt and need to be washed immediately. Call a service technician. |

^a The reset button is located on the bottom of W8600F. After the prefilters and cells are cleaned and reinstalled, press this button to turn off the SERVICE indicator and reset the wash frequency timer.



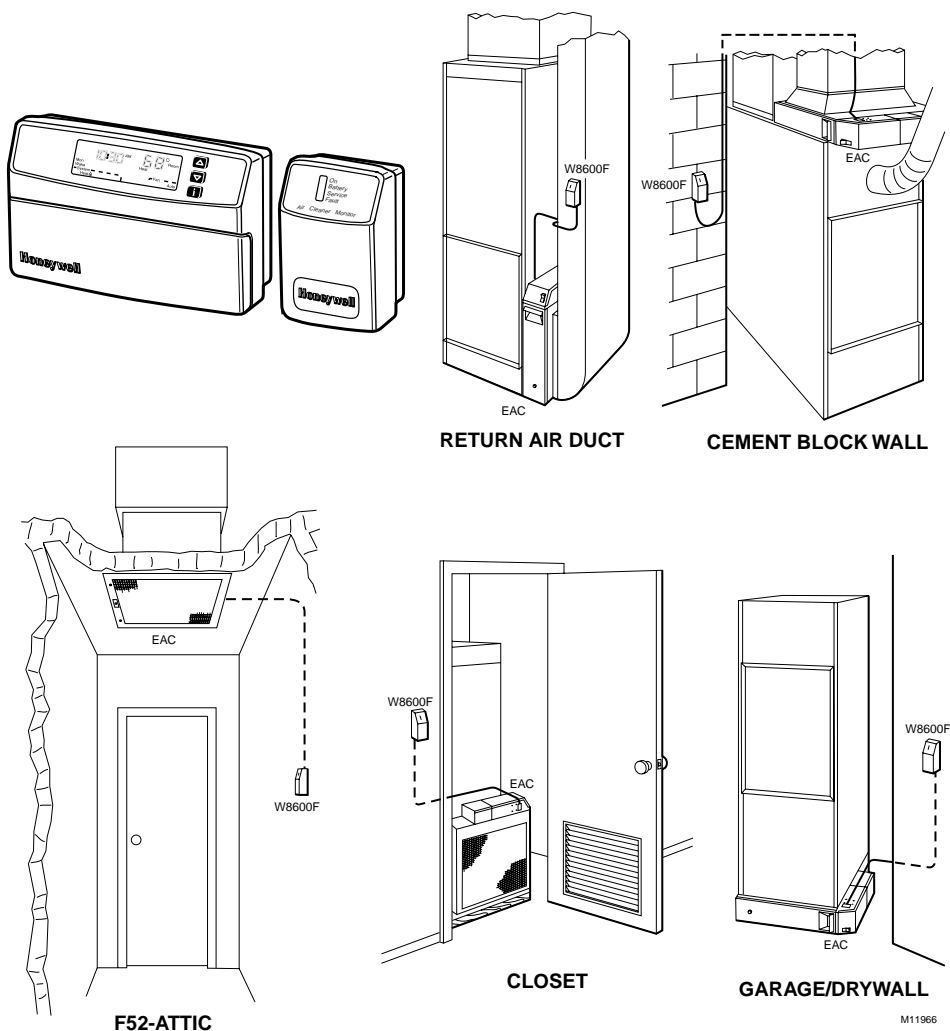

Fig. 2. W8600F mounting locations.

Mounting

The following mounting instructions assume that the W8600F is mounted next to a T8600 Thermostat. If installing the monitor at another location, modify the procedure to fit the installation.

1. Hold the mounting template (included in the W8600F kit) next to the T8600 as shown in Fig. 3.
2. Mark the holes for the screw anchors and the 3-conductor thermostat cable.
3. Remove the template and drill the holes.
4. Remove the W8600F from the base.
5. Position the W8600F base over the holes and install the anchors and screws (included in the bag assembly). Tighten the screws until the base is mounted firmly on the wall.

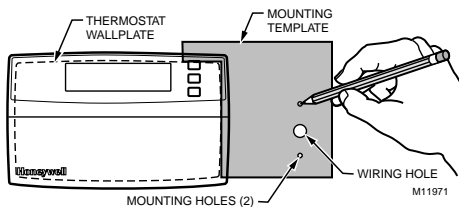

Fig. 3. Positioning mounting template.

Select Wash Frequency

Use the W8600F DIP switches to program the time between SERVICE indications. Be sure to select the setting according to the conditions of the home. Factors to consider include the duty cycle of the EAC, the number of people and pets, and activities such as woodworking and other crafts that are being done in the home.

Refer to Table 2 to select the wash frequency. Set the W8600F DIP switches to match the selection. See Fig. 4. The time listed represents actual run time of the EAC, not calendar days.

Table 2. Wash Frequency Options.

| DIP Switch Settings | | | Wash Frequency Days (Run Time) |
|---------------------|-----|-----|--------------------------------|
| 1 | 2 | 3 | |
| Off | Off | Off | 10 |
| On | Off | Off | 20 |
| Off | On | Off | 30 |
| On | On | Off | 40 |
| Off | Off | On | 50 |
| On | Off | On | 70 |
| Off | On | On | 100 |
| On | On | On | 180 |

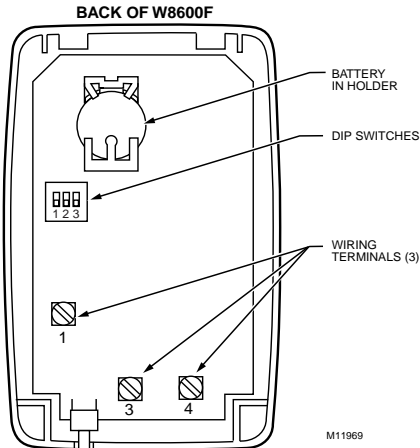

Fig. 4. Back of W8600F.

Wiring

1. Run a 3-conductor thermostat cable (up to 18 gauge) from the W8600F to the terminal strip on the air cleaner.

IMPORTANT

Connect cable to W8600F before attaching to the air cleaner terminals to minimize the risk of damage due to static electricity.

2. Connect the wires to terminals E1, E3 and E4 on the W8600F. See Fig. 4.

3. Check that the battery is correctly installed in the W8600F battery holder.
4. Snap the W8600F onto the base.
5. Turn off the power for the EAC.

⚠ WARNING

Electric Shock Hazard.

Can cause electrical shock or equipment damage.

Disconnect EAC power and open the access door before opening the power supply box cover.

6. Open the power supply box cover.
7. Remove the plug from the side of the power supply box (plug can be a metal knockout or a blank terminal strip).
8. Install the terminal block/cable assembly supplied with W8600F kit.
9. Plug the connector on the end of the cable assembly into the J2 terminal on the driver board (included with W8600F kit). See Fig. 5.

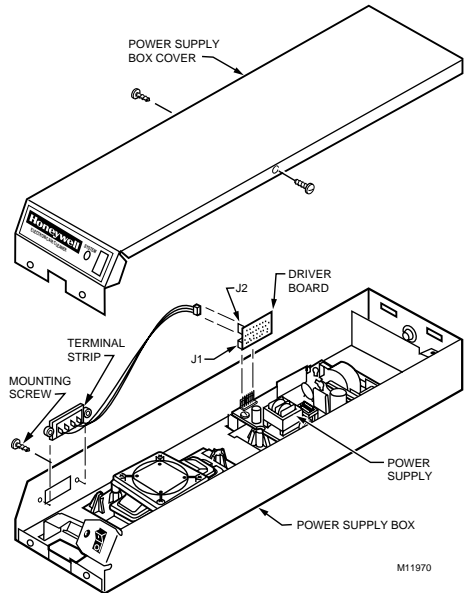

Fig. 5. Installing the driver board on the EAC.

10. Plug the driver board assembly into the J1 power supply connector.
11. Replace the power supply box cover.
12. Connect the three wires from the W8600F to the EAC terminals 1, 3 and 4.

NOTE: Connect terminal 1 to 1, 3 to 3 and 4 to 4.

13. Turn on the EAC power.
14. Turn on the system fan.
15. Push the W8600F reset button. All four indicators on the display will flash 5 times. The ON indicator will stay active as long as the EAC and the system fan are on.

SYSTEM CHECKOUT

Checkout (With EAC Running)

1. Be sure the battery is installed in the W8600F.
2. Press the reset button on bottom of the W8600F. All four indicators on the display will flash five times and then ON and FAULT will remain indicated.
3. Connect terminal 3 to terminal 4 and the function panel indicates ON. FAULT will turn off.
4. Disconnect terminal 3 from terminal 4. The W8600F is functional.

Checkout (Without EAC)

1. Be sure the battery is installed in the W8600F.
2. Press the reset button on the bottom of the W8600F. All four indicators on the display will flash five times, then ON and FAULT will remain indicated.
3. Connect 9 Vdc to terminal 4 with terminal 1 as ground (use a 9-volt transistor battery). The function panel indicates ON and FAULT.
4. Connect terminal 3 to terminal 4 and the function panel indicates ON, FAULT will turn off.
5. Remove 9 Vdc input. The W8600 is functional.

TROUBLESHOOTING

Refer to Table 3.

Table 3. W8600F Troubleshooting Information.

| Display | Condition | Solution |
|--|---|---|
| Blank | EAC is not operating. | Turn on EAC. Function panel indicates ON. Press W8600F reset button. DISPLAY flashes five times. |
| | ON indicator does not flash when reset button is pressed. | Check W8600F battery for 2.7 volts. Replace with BR2032 lithium battery if necessary. |
| All four indicators flash after pressing reset button, but ON is not displayed with EAC operation. | Voltage between W8600F terminals 1 (ground) and 4 (+10 to +15 Vdc). | Replace W8600F. |
| | No voltage, low voltage or wrong polarity. | Check wiring between W8600F and EAC. Correct wiring, if necessary. |
| | No voltage between EAC terminals 1 (ground) and 4 (+10 to +15 Vdc). | Check the driver board and cable installation. Correct installation if necessary. |
| BATTERY, SERVICE or FAULT, but not ON | Incorrectly wired. | Check wiring between W8600F and EAC. Correct wiring, if necessary. |
| ON and BATTERY | Bad battery. | Check W8600F battery for 2.7 volts. Replace with BR2032 lithium battery, if necessary. |
| ON and SERVICE | EAC cells and prefilters are dirty. | Wash and reinstall the EAC cells and prefilters. Press the W8600F reset button. ON flashes five times and SERVICE is off. |
| ON and FAULT | Damaged cells. | Repair or replace cells. |
| | Power supply problem. | Press EAC test button and verify output voltage. Replace power supply, if necessary. |

Honeywell

Home and Building Control

Honeywell Inc.
Honeywell Plaza
P.O. Box 524
Minneapolis, MN 55408-0524

Home and Building Control

Honeywell Limited-Honeywell Limitée
155 Gordon Baker Road
North York, Ontario
M2H 3N7